

EcoZone System

ME-6668

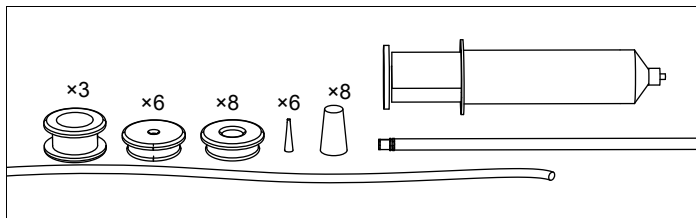

Included Equipment

- 3 EcoChambers with lids
- Tray
- 3 grommets for coupling chambers
- 28 assorted stoppers for closing unused holes (6 small probe stoppers, 8 large probe stoppers, 6 small stoppers, 8 large stoppers)
- Cotton rope for wicking moisture between chambers, 900 cm
- Syringe and plastic tubing with connector for sampling

water, replenishing water, and injecting pollutants

Recommended Equipment

- PASCO Interface
- PASCO Data Collection Software
- Advanced Water Quality Sensor (PS-2230)
- Oxygen Gas Sensor (PS-2126A)
- Carbon Dioxide Sensor (PS-2110)
- Temperature Sensor (PS-2125)
- Weather Sensor (PS-2154A)
- Turbidity Sensor (PS-2122)
- Water Quality Colorimeter (PS-2179)
- ezSample Water Quality Testing Kits:
 - Iron (EZ-2331)
 - Nitrate (EZ-2333A)
 - Ammonia (EZ-2334)
 - Phosphate (EZ-2337)
 - Chlorine (EZ-2339A)

See the PASCO website at

www.pasco.com

for more information about PASCO equipment.

Introduction

The PASCO ME-6668 EcoZones System is designed to help students model and understand the complex interactions within and among different ecosystems. The three clear acrylic EcoChambers are designed to accommodate PASCO sensors, making qualitative and quantitative measurements as easy as visual observation.

Students can measure many aspects of the traditional ecosystem—terrestrial, aquatic, and decomposition chambers. Students can also use each chamber individually by decoupling the chambers and constructing a single biome.

The unique design of the EcoZones allows the system to remain closed, which allows for measurements to have a minimal impact on the system. Environmental science probes can be used to actively measure variables in the ecosystem model. A syringe and tubing are included to extract water for chemical testing, replenished water without opening the system, and inject pollutants for chamber manipulation.

Set-up and Experiment Considerations

Before setting up the EcoZone System, there are some things that should be taken into consideration.

Consider what you are interested in measuring. There are nine open spaces available for sensors in the lids of the chambers. If you intend to measure water quality (dissolved oxygen, conductivity, etc.), consider using the Advanced Water Quality Sensor, which supports several different probes, instead of individual sensors.

A cotton rope is included to allow for efficient wicking of water from the aquatic chamber to the other chambers. Be sure that this wick covers each chamber sufficiently. Lay the wick underneath the plants both under and over the plants in the terrestrial chamber, for example, to ensure that plants receive sufficient water. Use approximately 36 inches of rope.

Caution: This wick is very efficient at moving water through the chambers. Do not use more than one strand, or you will deplete your aquatic chamber and flood the other chambers. Also, it is not necessary to completely submerge the wick in the aquatic chamber. Only a small amount of rope at the surface is needed to move the water. Recommendation: Test the wick first to determine how much is needed for your situation.

Cotton rope is used for its excellent wicking ability. However, cotton in contact with soil may decompose over a period of weeks. You may need to check and replace it periodically.

Equipment Set-up

Important: When carrying the EcoZone System, do NOT pick the system up by the aquatic chamber (the heaviest chamber). Pick the entire system up by the tray.

1. Place the three EcoChambers into the custom tray.
2. Connect the EcoChambers using the rubber grommets as illustrated.

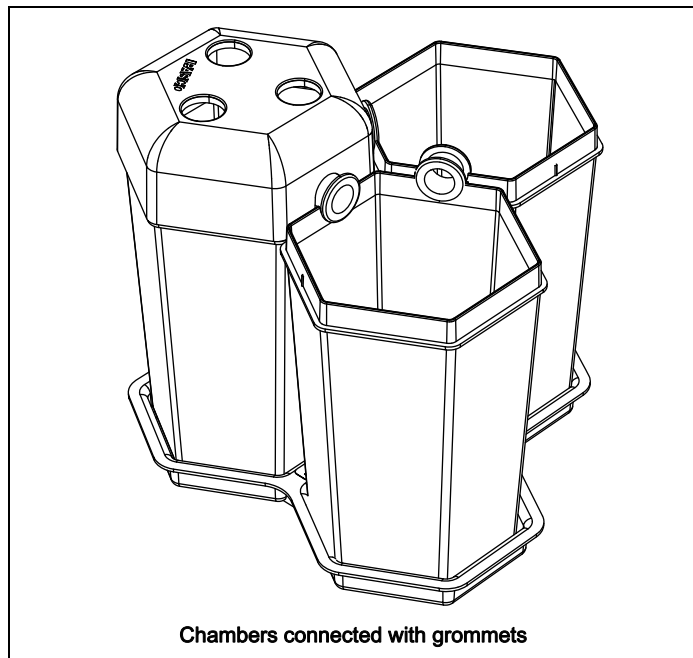

Chambers connected with grommets

3. Fill each EcoChamber according to the instructions in the lab you are performing.
4. Select the sensors and interface that you intend to use for the experiment.
5. Place the lids onto the EcoChambers, lining up open arches at the bottom of each lid with the rubber connection grommets on the chambers.
6. Insert large stoppers with holes into the holes in the lids.
7. Insert probes into the holes in the stoppers.
8. Insert small solid stoppers into unused holes in the larger stoppers.
9. Connect the sensors to the interface.

Sensor Calibration

Calibrate sensors prior to using them in an experiment. Refer to the documentation provided with each sensor for calibration instructions.

Note: In most cases, sensors do not require calibration. If, for example, you wish to measure only relative dissolved oxygen changes, the sensor does not to be calibrated.

Data Analysis

Graphs showing two variables changing over time are most valuable in the EcoZones experiments because

they show the relationship between related quantities, such as oxygen and carbon dioxide concentrations, and how these relationships change over time.

Example Activities

- Construct a traditional ecosystem with aquatic, terrestrial, and decomposition chambers.
- Construct a single biome, such as a desert, tundra, or mangrove biome.
- Monitor the effects of light on the photosynthesis of a plant in a single chamber.

Sample Data

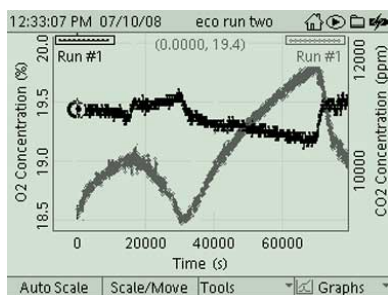

Concentrations of oxygen (black) and carbon dioxide (gray) change as a light is turned on and off.

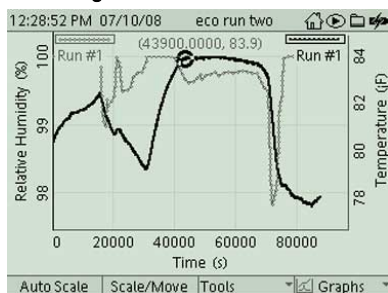

Relationship between the relative humidity (black) and temperature (gray) within a terrestrial chamber over 24-hours

Copyright

This document is copyrighted with all rights reserved. Permission is granted to non-profit educational institutions for reproduction of any part of this manual, providing the reproductions are used only in their laboratories and classrooms, and are not sold for profit. Reproduction under any other circumstances, without the written consent of PASCO scientific, is prohibited. Version: 2016-05-04.

Trademarks

PASCO, PASCO scientific, PASCO Capstone, SPARK SLS, SPARKvue and PASPORT are trademarks or registered trademarks of PASCO scientific, in the United States and/or in other countries. All other brands, products, or service names are or may be trademarks or service marks of, and are used to identify, products or services of, their respective owners. For more information visit www.pasco.com/legal.

Product End of Life Disposal Instructions:

This electronic product is subject to disposal and recycling regulations that vary by country and region. It is your responsibility to recycle your electronic equipment per your local environmental laws and regulations to ensure that it will be recycled in a manner that protects human health and the environment. To find out where you can drop off your waste equipment for recycling, please contact your local waste recycle/disposal service, or the place where you purchased the product.

The European Union WEEE (Waste Electronic and Electrical Equipment) symbol (to the right) and on the product or its packaging indicates that this product must not be disposed of in a standard waste container.

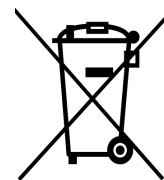

Technical Support

For assistance with any PASCO product, contact PASCO at:

Address: PASCO scientific
10101 Foothills Blvd.
Roseville, CA 95747-7100

Phone: 916-786-3800 (worldwide)
800-772-8700 (U.S.)

Web: www.pasco.com

Email: support@pasco.com

Limited Warranty

For a description of the product warranty, see the PASCO catalog.